

Design Acceptance Example Electrical Circuit Diagram

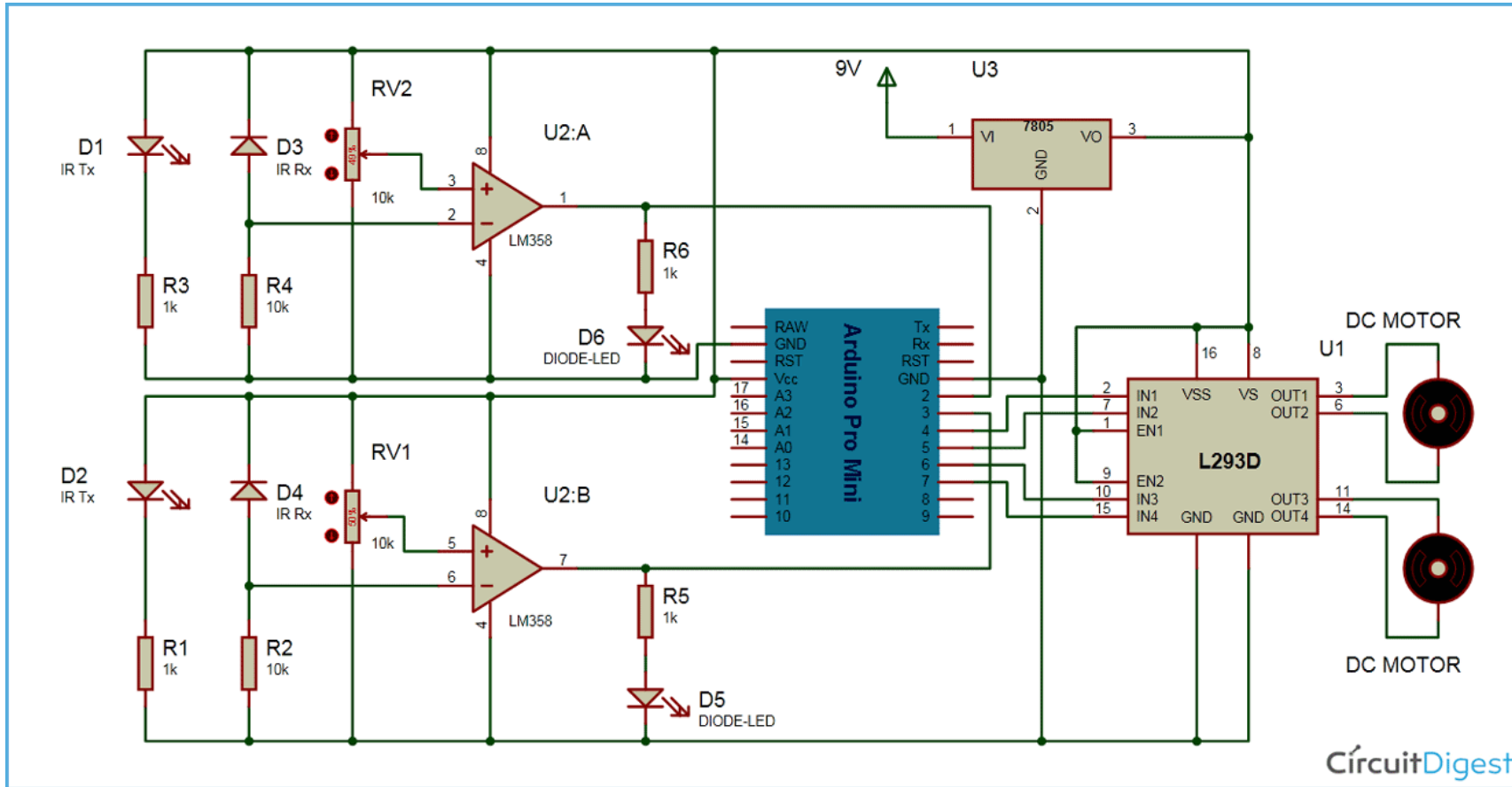

Notes:

- Each part is labelled (with part number where appropriate)
- All pins are label
- Power rails are labelled
- Clearly laid out
- Values of resistors (or range of potentiometers give)

Design Acceptance Example

Electrical Layout Diagrams

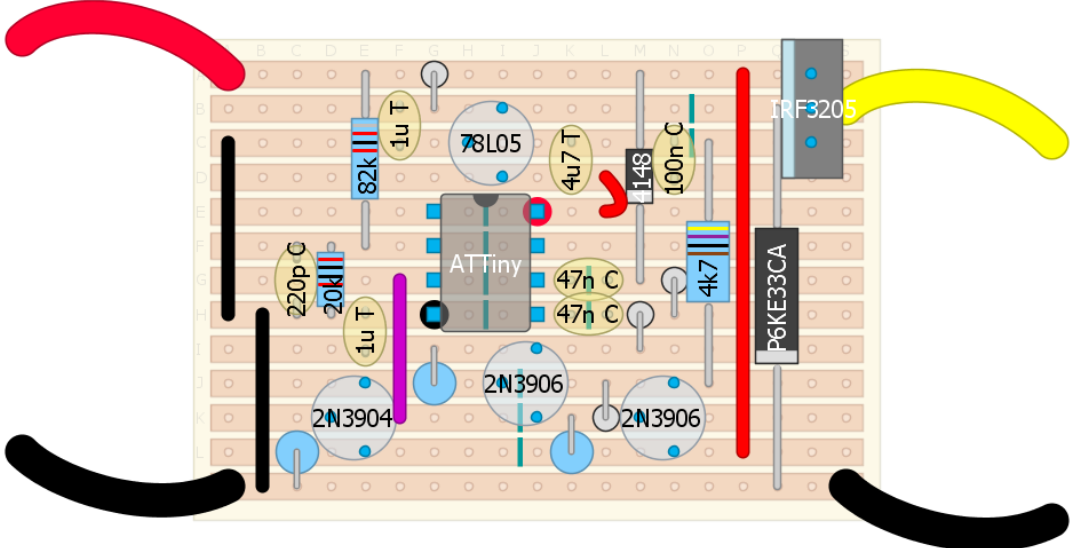

Notes:

- Power lines and connections shown
- Location of parts
- Track breakages shown

- Connectors should be considered such that electronics can be separated from the robots
- Keep layout tidy to use straight jumpers (try and avoid diagonals)